

Outdoor Free Cooling Unit 48EC

ODU 6L 48EC



Eng

Installation, Operation and Maintenance instructions

Introduction

This document covers the installation, operation and maintenance of Air-Site® ODU 48EC Free Cooling units. It consists of basic information and recommendations concerning design, installation and operation to ensure proper operation of the unit.¹

Please make sure to study this document thoroughly and follow all given guidelines and comply with the safety requirements.

Index

Drawing of ODU 6L 48EC.....	3
Drawing of DeltaManager 48 V.....	3
Accessories.....	4
Principle diagram	5
Product information.....	6
Installation	9
Controlling DeltaManager.....	11
DeltaManager Control Unit Functional description	11
X04 Control Unit Functional description	13
Air-Site® DeltaManager Advanced Setup.....	15
Maintenance, service and repair	16
Accessories and options.....	16
Connection diagram - DeltaManager	17
Drawings on intake/exhaust cowls	19
EC Declaration of conformity	20

Note! Any maintenance or installation must be done by a qualified or well instructed personnel.

Before energizing:

- Make sure that the intake cowl is mounted, the filter is installed and the ODU unit is locked, in order to protect personnel against unintentional contact with fan parts in motion. There is risk for personal injury if a body part comes near the fan parts.



Before performing any installation or service, please make sure that:

- The power supply is off (Switch disconnecter or unplug plug/socket etc.)
- The fan impeller has come to a complete standstill
- You observe all personnel safety regulations!



When working near ODU 48EC's lower parts:

- Be careful about hitting your head and shoulders in ODU housing edges, corners or the intake cowl.



When installing sheet metal parts with sharp edges:

- Use protective gloves.



When changing filters:

- Use protective gloves to prevent your body from soil and bacteria.
- Gently lower the old filter bags in a plastic bag and seal it immediately.



¹ Air-Site reserves the right, without prior notice, to make changes and improvements to the contents of this manual.

Drawing of ODU 6L 48EC

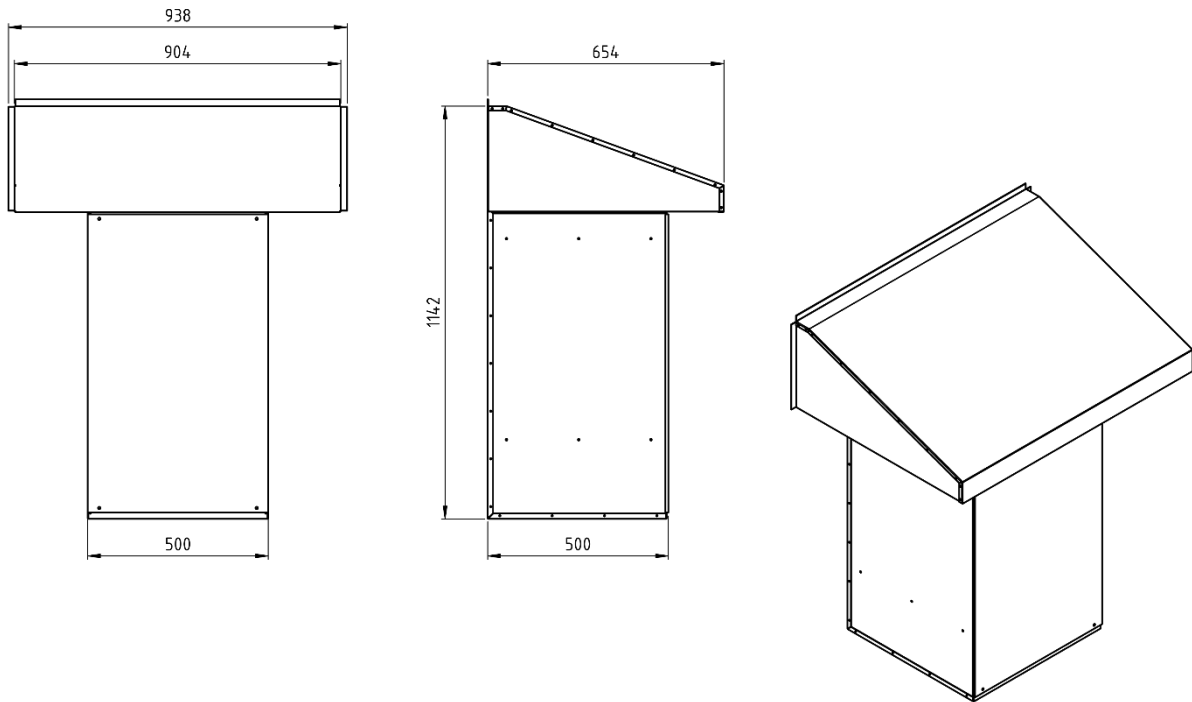

Drawing of DeltaManager 48 V

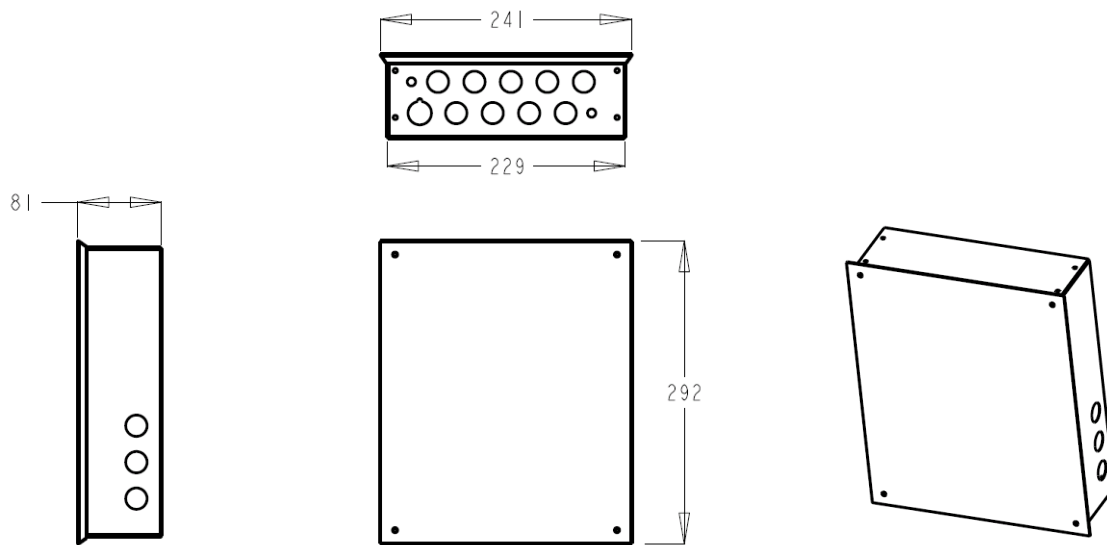

Accessories



Exhaust backdraught damper



Damper with motor



Fan heater 1300W



Fire damper



Smoke detector



Exhaust cowl



Power converter 230V/48V



GSM/GPRS SIOX modem

Principle diagram

The system is intended for climate control in equipment-, server rooms and alike.

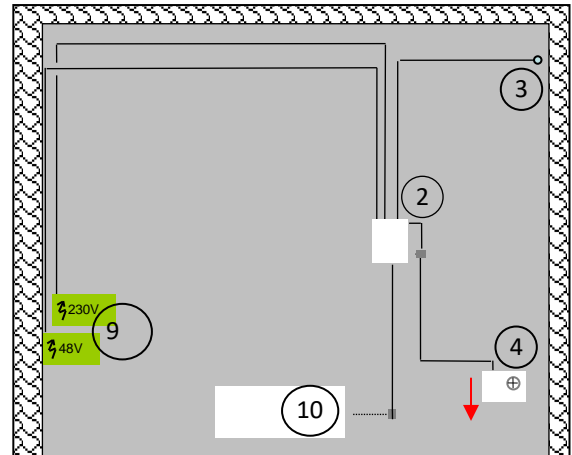
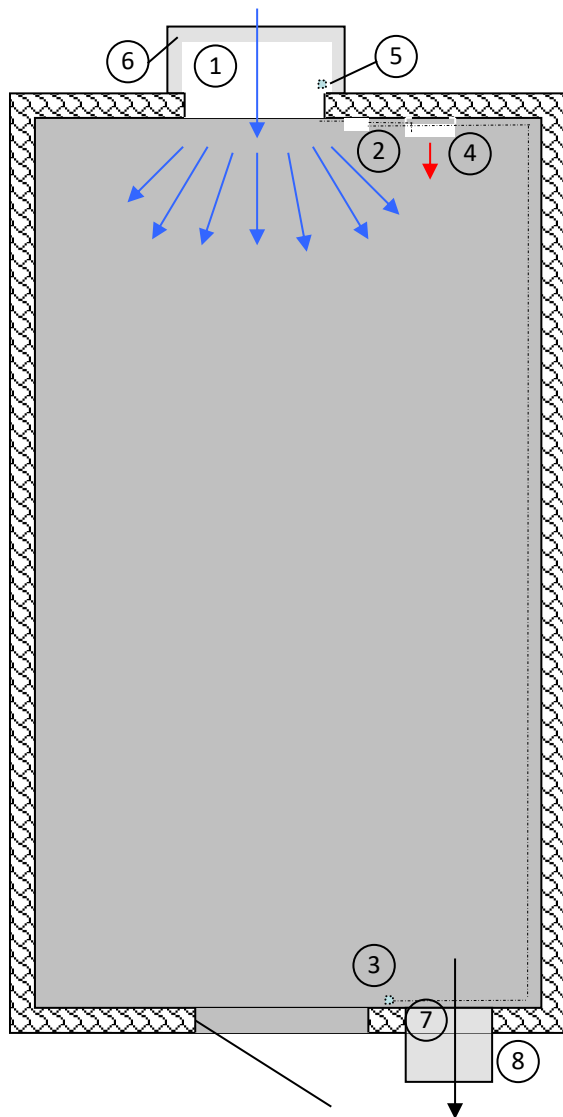

1. ODU
2. DeltaManager control unit
3. Indoor temp. sensor
4. Electric fan heater
5. Outdoor temp. sensor
6. Air intake cowl
7. Exhaust backdraught damper
8. Exhaust air cowl
9. Power supply
10. Inlet

Product information**ODU 6L 48EC****Contents:**

- Magnelis C5 fan housing
- EC-fan with external rotor motor
- 1 pc M6 Filter 490x490x360
- 1 pc NTC outdoor temp. sensor

Electrical data fan unit:

- Voltage 48 V
- Rated power 290 W
- Rated current 6,1 A
- Speed 1760 rpm
- Sound pressure 61 dBA

Fan unit, air flow, dimensions and weight:

- 830 l/s with clean filters
- Permitted ambient temp. -25°C ... +50°C
- Dimensions: See drawing on page 3
- Weight 26 kg
- Max. cooling power capacity 5-6 kW at $\Delta T = 2-5 \text{ K}$

Classifications according to IEC:

- Fan motor: IP42
- Temperature sensor: Protection Class II
- Connectors: IP20
- DeltaManager: IP54

Product information**DeltaManager Control Unit 48V****Control unit for:**

- ODU fan
- Motorized dampers
- Heaters
- AirCondition (option)

Functions:

- Advanced fan control/readout
- Logging of A- and B-alarms
- MODBUS TCP/IP compatible
- Readout/control via Ethernet port
(Software available at www.air-site.com)

Component list (connection diagram on page 17):

- RJ45 Ethernet communication port
- Terminal connections (see connection diagram)
- Relay/s for heater/AirCond (see connection diagram)
- 12 pcs cable glands Klikseal M20
- Indoor temp. sensor with 8 m cable
- Alarm relays
- 2 m four conductor cable with connector for fan
- 2 m two conductor cable with connector for outdoor temp. sensor (integrated in fan)

TCP/IP connection, see page 11

Functional description, see page 11

Function software, see page 15

X04 Control Unit

Regulator with internal indoor temp. sensor. 8 m cable (EKKX 4x2x0,5) for connection between X04 and connection box is included in the "Connection Box" article. See page 18 for circuit diagram.

Contains:

- Alarm relay
- 0...10 V output for fan speed
- Start signal for heater and AirCond
- SIOX communication port

Connection box 1R

To be placed near the ODU unit. Plug in EKKX between connection box and X04 (included). The fan cables are equipped with quick connector. Connectors and extension cord are also included in Air-Site's fan heater article. Circuit diagram on page 18.

Component list:

Plastic enclosure 125x125 mm
 DIN-rail with terminal connections
 Relay for heater or AirCond (≤ 10 A)
 6 pcs cable glands Klikseal M20
 2 pcs fan wires (W1.1 & W2.1, see circuit diagram)
 8 m cable (W1, EKKX 4x2x0,5, see circuit diagram)

Connection box 2R**Component list:**

Plastic enclosure 125x170 mm
 DIN-rail with terminal connections
 2 pcs relays for heater, AirCond (≤ 10 A) or damper
 7 pcs cable glands Klikseal M20
 2 pcs fan wires (W1.1 & W2.1, see circuit diagram)
 8 m cable (W1, EKKX 4x2x0,5, see circuit diagram)

Electric fan heater



ELECTRICAL DATA

- Voltage 1~230 V
- Power: 1,3 kW
- Rated current at -25°C = 5,65A

DIMENSIONS AND WEIGHT

- Width 177 mm
- Height 221 mm
- Depth 89 mm
- Weight 1,0 kg

230-48V power converter

IP20-320

For ODU 6L



IP20 casing incl. wiring and wall brackets.

OUTPUT

DC VOLTAGE	48V
RATED CURRENT	6,7A
CURRENT RANGE	0-6,7A
RATED POWER	321,6W
RIPPLE & NOISE (max.) Note.2	240mVp-p
VOLTAGE ADJ. RANGE	41-56V
VOLTAGE TOLERANCE Note.3	±1%
LINE REGULATION	±0,2%
LOAD REGULATION	±0,5%

INPUT

VOLTAGE RANGE	230VAC
FREQUENCY RANGE	47-63Hz
POWER FACTOR	>0,95
INPUT EFFICIENCY (Typ.)	89%
INRUSH CURRENT (max.)	40A
LEAKAGE CURRENT	1mA

PROTECTION

Over load	105-135% rated output power
Protection type	Hiccup mode, recovers automatically after fault condition is removed.
Over voltage	57.6 ~ 67.2V
Protection type:	Shut down o/p voltage, re-power on to recover
Over temperature	80°C±5°C
Protection type	Shut down o/p voltage, recovers automatically after temperature goes down.

ENVIRONMENT

WORKING TEMP.	-20 ~ +65°C (Refer to output load derating curve)
WORKING HUMIDITY	20 ~ 90% RH non-condensing
STOR. TEMP. HUMIDITY	-40 ~ +85°C, 10 ~ 95% RH
TEMP. COEFFICIENT	±0.03%/C (0 ~ 50°C)
VIBRATION	10 ~ 500Hz, 2G 10min./1cycle, 60min. each along X, Y, Z axes
MTBF	207K hrs min.
	MIL-HDBK-217F (25)
Dimension	266*115*50mm (L*W*H)

Note:

1. All parameters NOT specially mentioned are measured at 230VAC input, rated load and 25 of ambient temperature.
2. Ripple & noise are measured at 20MHz of bandwidth by using a 12" twisted pair-wire terminated with a 0.1uf & 47uf parallel capacitor.
3. Tolerance: includes set up tolerance, line regulation and load regulation.
4. The power supply is considered a component which will be installed into the final equipment. The final equipment must be re-confirmed that it still meets EMC directives.

Installation instructions

Fan unit:

Cut a 460x200 mm hole in the wall, approximately 40 cm above the inner floor (hole center).

Mount the wall led thru (included) in the 460x200 mm hole. In order to prevent fiber release from wall insulation. Insert from the outer wall and cut protruding metal if needed.

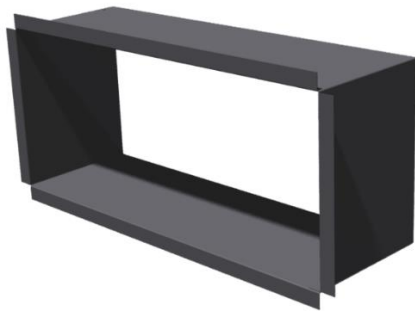

Fig. 1: Wall led thru

Unscrew the outer panel off the ODU and fasten the ODU on the wall with so many screws needed to make it tight and in level with the inlet hole. Seal between the wall led thru and ODU to protect against rain and reduce the risk of small animals to enter. Screw the outer panel back to the ODU again.

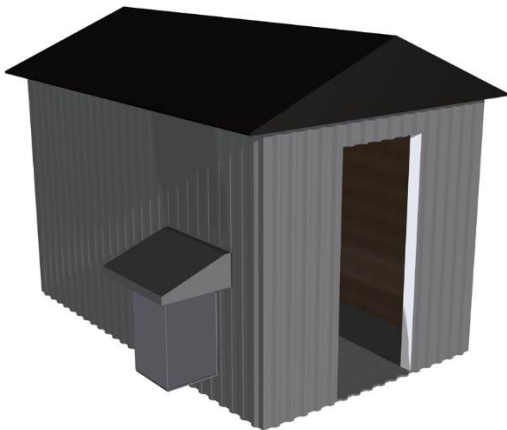

Fig. 2: ODU with intake cowl mounted on wall

Pull the ODU cables through the wall hole and hold them in the U-shaped hole while fastening the indoor grid to the wall using six (6) screws.

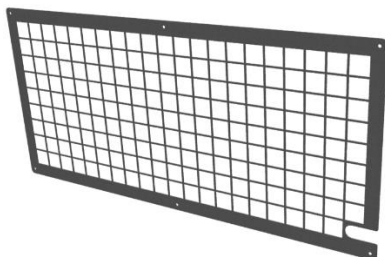

Fig. 3: Indoor grid

Note! Do not turn on the power until the outer panel and the indoor grid are completely fastened!

Electric air heater

Mount the fan heater unit with the supplied wall plate, with the air stream direction towards the floor. Air-Site Heater includes a 2 m cable with prepared plug for easier connection.

Exhaust cowl and backdraught damper

Cut a hole in the wall so that the exhaust cowl fits (500x400 mm). **Note!** The distance between the hole bottom edge to the floor should be at least 1600 mm.



Fig. 4: Exhaust cowl 500x400

Mount the backdraught damper* into place with cowl mesh on the inside of the outer wall. Mount the exhaust cowl. Use sealing between cowl and outer wall.



Fig. 5: Backdraught damper mounted in wall

* Air-Site delivers telescopic backdraught dampers as standard, which means that one part is mounted from the inside and one from the outside. So-called Basic dampers (w/o telescope) also occur in some cases. Basic dampers are

mounted from the inside so that the louvers open outwardly to the cowl.

Mount rain protection sheet if needed. Seal between all open areas.

Control unit; Alt. DeltaManager

Mount DeltaManager near the ODU fan unit. Connect cables according to the connection diagram on **page 17**. 230 V and 48 V power supply cables are not included. Supply cable for the heater is included with the heater.

Outdoor temperature sensor and fan are mounted inside the ODU fan unit. Connect these to the DeltaManager using the included quick connectors.

Indoor temperature sensor (8 m cable from DeltaManager) is to be mounted as far away from ODU – and near the exhaust air - as possible, on the wall 1.5 m above the floor.

Control unit; Alt. X04 with connection box

Mount the connection box near the ODU fan unit. Connect cables according to the connection diagram on **page 17**. 230 V and 48 V power supply cables are not included. Supply cable for the heater is included with the heater.

Outdoor temperature sensor and fan are mounted inside the ODU fan unit. Connect these to the connection box using the included quick connectors.

Mount X04 on the wall, 1.5 m above the floor. Place X04 as far away from ODU – and near the exhaust air – as possible. Use countersunk screws when mounting the X04 casing on the wall, so that they do not damage the back of the circuit board.

Cable W1 (8 m) is to be connected according to the circuit diagram on **page 18**.

Electric supply:

The user must hold the following:

1. Selection, installation and connection of power cables for 48 V DC and 230 V AC. Minimum cable diameter is 1,5 mm² for both feeds. Maximum allowable voltage drop is 5 %.
2. The supply cables for 48 V DC and 230 V AC must be protected against overcurrent (set values for 48V should not exceed 6 A and must not exceed 10 A).
3. Automatic disconnection of 230 VAC supply in order to protect the personal safety against electric shock by indirect contact in

accordance with EN IEC 60204-1 section 6.3.3 (equivalent to IEC 60364-4-41 section 413.1, or for Sweden SS 436 40 00 section 413.1).

Means for disconnection must be arranged in the feeding circuitry of 230 V AC and 48 V DC.

Such disconnection devices shall preferably be made in accordance with EN IEC 60204 1 section 5.3: "Supply disconnecting (isolation) device".

Since risks of mechanical maintenance work on a "Free Cooling Unit" like this are small, they can also be carried out under IEC 60364 5 53 section 536.2 "Isolation" or SS 436 40 00 section 536.2 "Separation".

A possible solution with plug connections must not allow confusion between the means of connection for 230 V AC and 48 V DC.

Accessories instruction:

Please contact Air-Site for installation instructions regarding these accessories:

- Smoke detector
- Fire damper installation
- Intake and Exhaust cowls

Controlling DeltaManager

via Ethernet port in Microsoft Windows

1. Download and install the software Air-Site® Visual Viewer from www.air-site.com (Free). A reboot may be required
2. Start the setup form file **DeltaManager Advanced Setup** (as described on page 15) Press [F6] (it is also possible to right-click an open space and choose SiouxBus). Select **Net** under ComMode
3. Enter the following information:
 - a. Server Address: 192.168.1.234
4. Click ReInit. Online indication
5. Click Close
6. Follow the instructions on page 15

Note!

DeltaManager uses a built-in DHCP server. It will automatically assign an IP address to the connecting computer. Advanced network knowledge is not needed.

But, if the DeltaManager is connected to a modem or a superior system such as a SCADA system, it is highly recommended that the DHCP server is disabled (tab 7 on page 15).

Contact Air-Site if support is desirable.

DeltaManager Control Unit Functional description

Air-Site® DeltaManager is a control unit equipped with analog and digital I/O features, and RJ45 connector for Ethernet communication.

One outdoor- and one indoor temperature sensor are connected to the DeltaManager. The sensors use NTC thermistors. The DeltaManager controls fan, dampers, heaters and optional AirCondition.

Delta Manager communicates via Ethernet, which allows you to change operating parameters and check status by using the Windows® based configuration software, called "Setup Form". The module can also communicate via MODBUS TCP for connection to a host system.

A keypad with four buttons and three LEDs are used for basic operation and indication such as service stop request, activation of test sequences and operation/alarm indication.

The PCB also has a built-in real time clock that can be used to time stamp logs. Power supply of the clock is maintained by means of a so-called "supercap", which is a capacitor with very high capacitance. The capacitor charges as soon as the PCB is powered on and can supply the clock for at least two weeks in case of power failure. This may seem short, but for systems that are normally continuously energized, this option is better than batteries because of its lifetime.

If the control board microprocessor should fail, there is a built-in feature that ensures the fan to run at Maximum speed for cooling to be maintained and avoid dangerous high temperatures.

Note that the earth plane of the PCB is electrically separated from the enclosure of the DeltaManager. This enables the DeltaManager to be supplied by a 48 V DC system that is earthed at the positive pole.

Where the positive pole of a 48 V DC supply is earthed:

- **Protective earth conductors may only be connected to terminals marked PE**
- Where a possible addition or replacement with a different kind of external component is made, assure that there is no electrical connection between its signal ports and its chassis. Such a connection will cause short-circuit of the power supply system at the source (the battery).
- Check, after installation but before 48 V DC is applied to DeltaManager, that no connection exists between the protective bonding system of the site and terminal X1:- (i.e. terminals marked with the "-" minus sign in terminal row X1)

For all handling of the PCB, standard ESD protection measures must be adopted.



Fan Control

ODU fan speed is controlled either with or without ΔT regulation. Max/min speed can be adjusted from the Air-Site® software. ΔT regulation saves energy and reduces noise from the ODU unit. If ΔT regulation is switched on, the calculated set point shifts depending on outside temperature.

New calculated set point (determines speed) is the sum of the ΔT value (2K) and current outdoor temperature. Calculated set point is never allowed to be lower than the set point (Adjustable, but comes with a standard setting of 23°C). In case of outdoor temp. sensor fail, the ΔT regulation is turned off and regulation is controlled by the set point. If ΔT regulation is switched on and the outside temperature exceeds 20°C the Free Cooling Unit will not completely turn off, it runs with a speed of 20 % of faster depending on the entered setting (adjustable).

Heater

When the inside temperature is below the threshold, the heater is automatically activated.

Air-Condition (AC)

In case of Air-Condition use, the *AirCond Mode Status* under the *AirCond* tab in the *setup form* (DeltaManager Advanced Setup) must be selected. Either select:

Mode A) The AC is driven by indoor temperature. A start signal is given to the AC when the temperature is higher than the reference value + Pband + dead zone. The AC is then active for a predetermined time (usually 180 minutes). During this time the AC is controlled by its own internal control system. In case the indoor temperature sensor fails, the AC will not start. If the AC does not have a built-in control system, a hysteresis can be set. The relay starting/stopping the AC is controlled by the power controller around the set point -.

Mode B) The AC is driven by outdoor temperature. This mode requires installation of a temperature sensor on the outside of the fan casing, but out of reach of direct sun. This operation case is chosen by setting a new temperature limit value for *Outdoor* in the menu. If zero, the AC runs according to the temperature as Mode A. The AC will be given start signal when the outside temperature exceeds the specified temperature. Failure of outdoor sensor will set the AC to be controlled by the indoor temperature sensor.

In both modes, the ODU unit will automatically stop when the AC is given a start signal. If the indoor temperature is higher than 30°C more than 30 minutes after the AC start, the Free Cooling Unit will start again automatically.

Damper - Four modes of operation

DeltaManager damper output can power 24 VDC/0,5A \approx 12W. The four operating modes are:

1. Back draught damper without motor.
2. Damper and motor with spring return. The damper is open when the room temperature exceeds set value (18°C), or by 230 V power failure.
3. RBS: When the outdoor temperature exceeds 15°C (adjustable) and the fan is running, the damper is open, and when the outdoor temperature falls below 15°C or if the fan is off, the damper is closed. Hysteresis 1°C.

4. MIX/Winter damper. Reversed RBS function. When the outside temperature falls below 15°C (adjustable) and the fan is running, the damper is open, and when the outdoor temperature exceeds 15°C or the fan is off, the damper is closed. Hysteresis 1°C.

The damper closes in case of fire if the signal for this has been linked.

For 2,3,4: If the damper has been at the same position for more than 48 h, fan regulation is interrupted and the damper is exercised by entered throttle opening time.

Service mode

The ON/OFF button is used to stop the ODU fan and Air-Condition unit for 15 minutes. Press again before time limit expiration for immediate start of the devices and to resume normal operation. The setpoint of the heater changes to 20°C during the service stop.

Test Mode

If the TEST button is pressed, the system goes into test mode. By pressing arrow-up and arrow-down you can move forward or backward in the test sequences. After 15 minutes without pressing any button, the system will return to normal operation. Return can also be obtained by pressing the ON/OFF button again.

- Step 1: Damper opens and the fan run at maximum allowable output.
- Step 2: Damper closes and the fan stops. Heater is activated
- Step 3: If AC is defined to be in the system, this step will start dito. If not, this step will be discarded. Damper closed, fan and heater turned off.
- Step 4: High temp. alarm activated
- Step 5: Low temp. alarm activated
- Step 6: Power failure alarm activated
- Step 7: Fire alarm activated
- Step 8: ΔT alarm (filter) activated
- Step 9: AC alarm activated
- Step 10: Fan alarm activated
- Step 11: Control Panel LED test

Alarms

The alarms are divided into A and B alarms. They each have their own alarm relay which uses a SPDT relay. You can thus have either a direct opening or closing function at alarm. Note that the relays are normally drawn in non-alarm condition.

- | | |
|----------|--|
| A alarm) | High temperature, low temperature, fire and 230 VAC power failure. |
| B alarm) | Indoor sensor fail, outdoor sensor fail, filter alarm, fan alarm and AC alarm. |

Fire/230 VAC power failure

Input DI2 can either work as fire alarm input or as an input that will tell if 230 VAC power supply is broken. Configuration of the function can be made under the *Alarms* tab in the *setup form* (Air-Site® software). An alarm contact (relay contact) is to be connected to the input, which is drawn in non-alarm condition.

- If DeltaManager is configured to use the Power failure function, this applies: Setpoint will increase by 12°C (adjustable) to save battery life. Fan runs at a maximum speed of 50 %. (adjustable). Air-Condition (if any) will be turned off. "230 VAC Missing" alarm is activated.

- If DeltaManager is configured to use the fire alarm function this applies: Fan, heater and Air-Condition (if any) is turned off. Damper closes and A alarm is activated.

High temperature - Damper opens and the fan run at maximum allowable output. When 230 VAC power failure is used, the fan uses the option "Max speed when 230 V AC is lost", as described above. AC is off.

Low temperature - Fan off and heater on.

Filter alarm

" ΔT Filter Alarm" decides upon which temp. difference (actual value MINUS set point with consideration to ΔT shift) AND if the fan runs at full speed when the filter alarms can be obtained. If high temp. alarm is activated, the filter alarm is masked. Examples of conditions are: Full filter, dirty intake grille, dirty intake mesh or when the Free Cooling Unit is under dimensioned.

Indoor temp. sensor fail

Damper opens and the fan run at maximum allowable output. "Max speed when 230 V AC is lost", as described above. AC is off.

Outdoor temp. sensor fail

In case of outdoor temp. sensor fail, the ΔT regulation is turned off and regulation is controlled by the set point. If ΔT is not used (ΔT set to 0°C) fan regulation is controlled according to the set point.

Fan alarm

Damper closes, fan stops and AC starts.

AC Alarm

The system runs in Free Cooling Mode.

Alarm memory & logging

Under tab 5 (Alarms) in the setup form, Alarm logging can be read. The log shows whether a particular type of alarm has occurred but may have gone back and therefore not visible in the usual alarm flags that shows current status. Click the "Clear Alarm List" to clear the log.

NOTE!

It is important that the clock is set at the first power-up of DeltaManager.

X04 Control Unit Functional description

Fan speed controlled by indoor/outdoor sensor.

The fan speed is controlled by the difference between indoor and outdoor temperature. As the indoor temperature increases so does the fan speed. As the temperature decreases so does the fan speed, until it reaches a minimum value (adjustable). If the heater is on, the FreeCooling fan is off.

The user-configurable delta T value denotes at which outdoor temperature below the selected set point that the regulator's set point value starts to be calculated as the sum of the outdoor temperature and the delta T temperature. Thus, the set point will follow the outdoor temperature at delta T degrees higher.

Heater

When the indoor temperature falls below 15°C (adjustable) the electric Heater/Fan unit is activated.

Air conditioning mode

Chose air conditioning mode in the Visual-SIOX software setup.

Air conditioner controlled by the indoor temp.

(Mode A)

Air Cond starts when the indoor temp is higher than the reference value + P-band + dead zone. Air Cond is then active during an adjustable period (180 minutes). During this period the Air Cond is controlled by its own internal control system. If the Air Cond equipment lacks an own control system, a hysteresis can be designated and the T10 relay that controls the Air Cond is switched on and off by the indoor temperature settings.

Air conditioner controlled by the outdoor temperature

(Mode B)

When this mode is chosen, it is pivotal to install the outdoor sensor out of reach of direct sun. This mode is chosen by setting a temperature limit value for the outdoor temperature in the menu. If the limit is set to 0, the Air Cond is controlled as in mode (A) above. In this mode the Air Cond starts when outdoor temperature is above the set temp. In case of malfunctioning outdoor sensor the AC is controlled by the inside temperature. In both A and B modes the fan unit is stopped when the Air Cond runs. If the indoor temp is higher than 30°C, 30 minutes after the AC has started, the fan unit will start again automatically.

Service timer

During normal operation, if the function button is pressed in for about 5 seconds, the free cooling fan is switched off for 15 minutes (adjustable). If the button is pressed again before this period has expired, the free cooling fan will restart.

Alarms

The alarm relay will close at power-on and open in case of an alarm. The relay is not latching; it will close again as soon as the causes for the alarm no longer exist.

A-alarm =the LED will signal a steady red light.

B-alarm =the LED will signal a flash red light.

High temperature

FreeCooling fan is running with high speed when high temp alarm is activated.

Low temperature

Heater is switched on, FreeCooling is off.

Filter alarm

The alarm relay opens when there is a certain Δt between indoor and outdoor temperature. Examples for such conditions are: full filter, dirty intake grill, dirty intake mesh or when the free cooling unit is under-dimensioned.

Test mode

During normal operation, if the function button is pressed in for about 10 seconds the test sequence will start.

Stage 1: Free cooling fan starts.

Stage 2: The heater unit starts.

Stage 3: Air-conditioning starts.

Stage 4: Testing the room high and low temperature alarm.

Move the lever to "max" for testing high temp alarm. Move the lever to "min" for testing low temp alarm.

Please press the function button once to step through the stages above. Normal operation starts after 30 minutes if no button is pressed.

Alarm and operations indicators

The led lights green when freecooling is activated and slowly flashing green when air-cond or heater is running. Service is showed by green flash fast short-long. All alarms have red lights

Main supply

24V/48V DC

Settings

Change settings via computer. Wire between X04 and computer.

Connections possibilities

- Serial connection to PC Visual SIOX.
- Connection to external modem.
- Connection to TCP/IP with external gateway.

Air-Site® DeltaManager Advanced Setup

Use **DeltaManager Advanced Setup** to read or change parameters of control unit **DeltaManager**. Temperatures, fans, Air-Conditioners, heaters, logs etc. can be controlled from here. Setup parameters and IP addresses can be changed in real time and the device can also be loaded with previously saved parameters.

Tab 1. Start

Overview over current alarm status, service stop, LED Status and current outdoor & indoor temperatures.

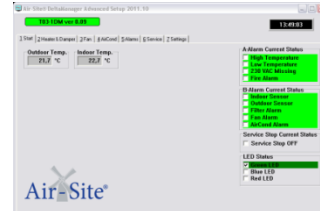

Tab 2. Heater & Damper

Displays settings for heater and damper. It is also possible to change these settings by writing a new value in a function box and pressing Return (Enter). The tab also shows current status of the heater and damper, as well as alarms and temperatures as mentioned in tab 1.

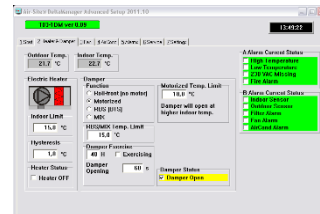

Tab 3. Fan

Displays settings for the ODU unit. It is also possible to change these settings by writing a new value in a function box and pressing Return (Enter). The tab also shows current status of the fan, as well as alarms and temperatures as mentioned in tab 1.

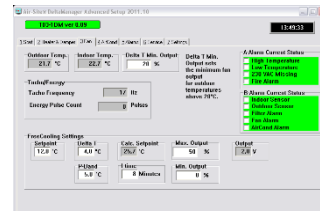

Tab 4. AirCond

Settings and status for AirCondition. Here you are able to choose between Mode A and Mode B according to the functional description on page 11, as well as settings for Emergency Cooling Fan Start. The tab also shows current status of the AirCond, as well as alarms and temperatures as mentioned in tab 1.

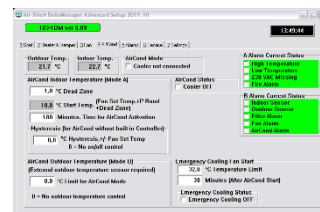

Tab 5. Alarms

Settings and status for alarms. It is also possible to change values for the filter alarm, temperature alarms, DI2 function and the ability to set desired room temperature at service stop. Alarm history of the last 10 alarms is placed at the tab bottom. Here you also have the ability to clear the alarm history. Alarms as mentioned in tab 1.

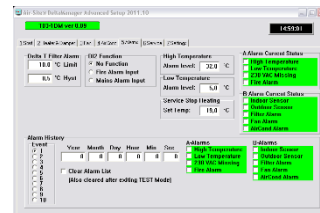

Tab 6. Service

All settings regarding service stop and test mode as mentioned in the functional description on page 11. One double-click in the Software Revision field shows the current software configuration. Here you also have the ability to set reduced fan speed at power failure. Alarms as mentioned in tab 1.

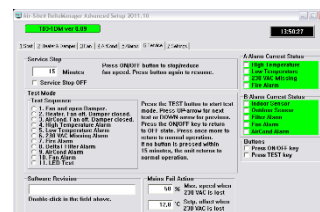

Tab 7. Settings

Settings for IP address, Real time clock (RTC) and button for module restart. Alarms as mentioned in tab 1.

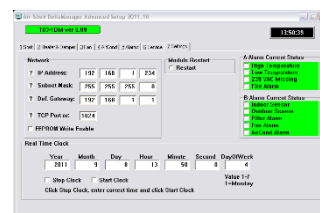

Maintenance, service and repair

Before performing any installation or service, please make sure that:

- Power supply is off (Disconnect or, plug/socket etc.)
- Fan impeller has come to a complete standstill
- You observe all personnel safety regulations!

Fan:

The fan should be cleaned when necessary to avoid unbalance and unnecessary damage to the bearings. The fan bearings are maintenance free and should only be changed if necessary. Do not use a High pressure cleaner (steam jet) when cleaning the fan! Make sure the fan impeller's balance weights are not moved or the fan impeller distorted. Listen for abnormal operating noise.

Filters

Filters should be changed at least once (1) every year or more frequently if needed.

Air intake

Inlet must be cleaned of leaves and dust to maintain a high air flow.

Exhaust air

Make sure the backdraught damper properly closes when the fan is cut off.

Accessories and options

- Intake cowl 900x290 mm with protective mesh (included)
- Intake/exhaust cowl 500x400 mm with protective mesh
- Exhaust backdraught shutter 500x400 mm
- Damper with motor (various sizes)
- Electric air heater 1300 W
- 230-48V power converter IP20-320
- Smoke detector
- Spare filter F7 490x790x360-7
- Fire damper kit (various sizes)
- Communication kit (for X04 and T10)
- 3G Modem for IP communication

Connection diagram - DeltaManager

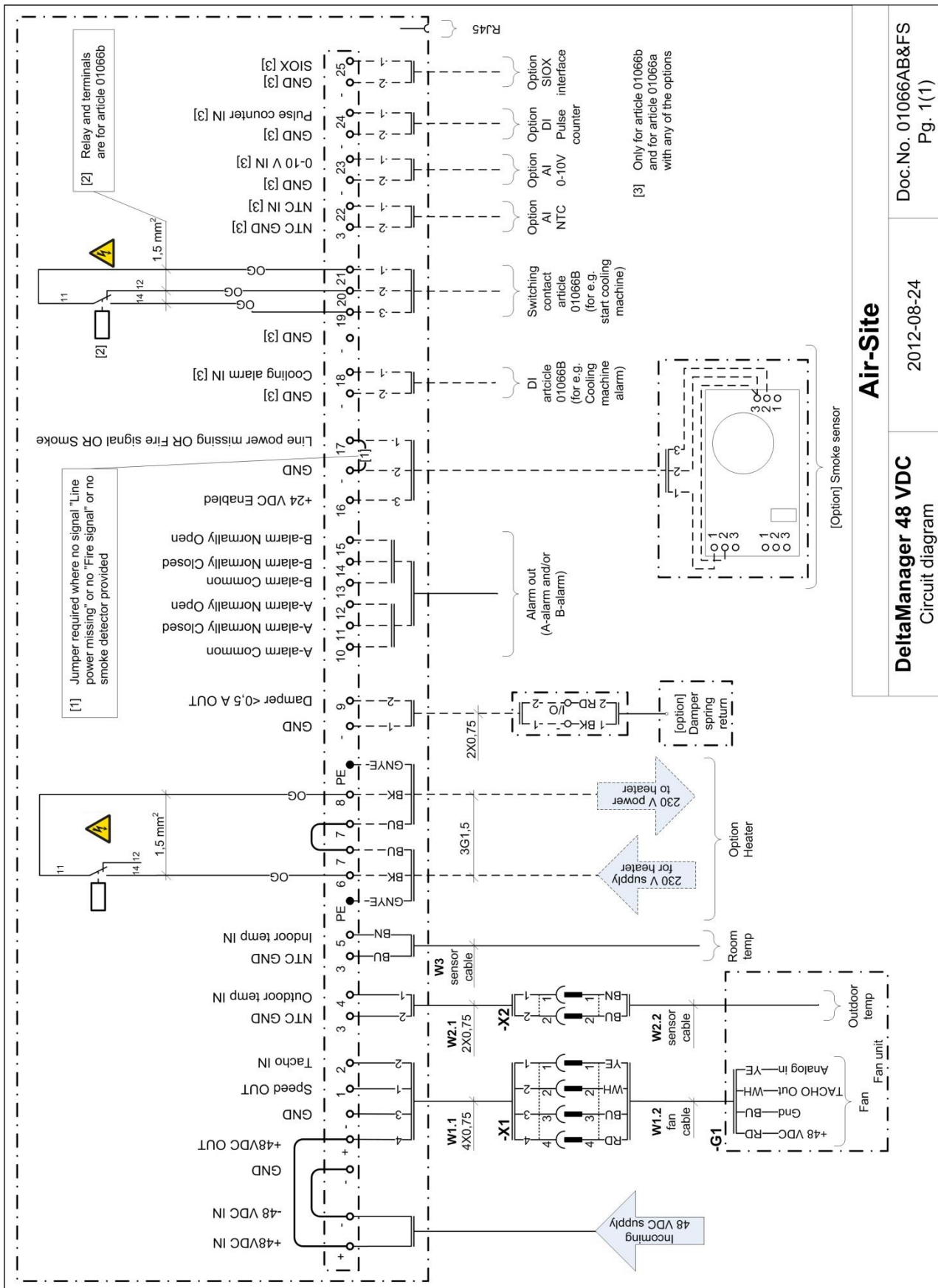

Air-Site

Doc.No. 01066AB&FS
Pg. 1(1)

2012-08-24

DeltaManager 48 VDC
Circuit diagram

Circuit diagram - X04 with connection box

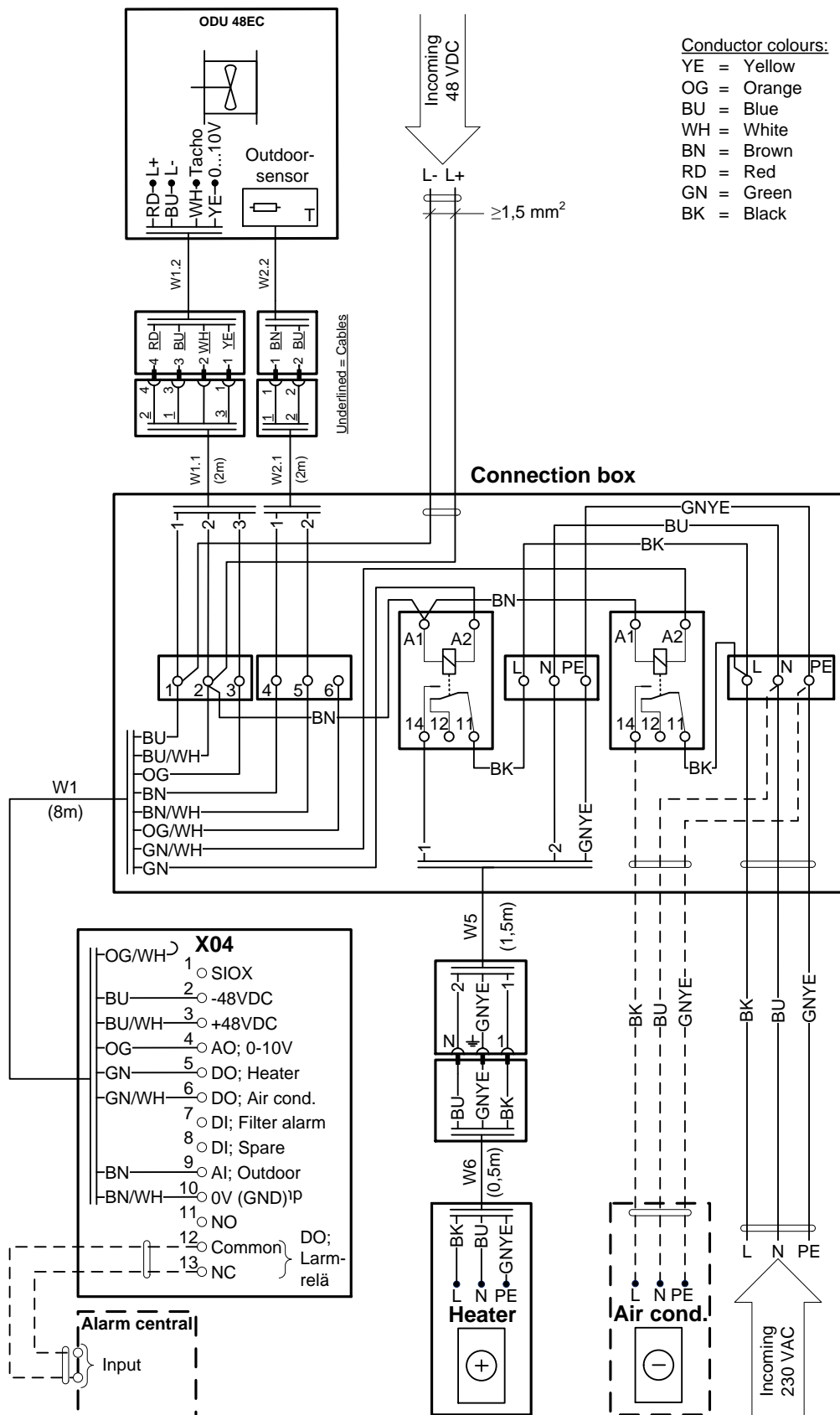

Drawings on intake/exhaust cowls

Intake cowl 900*290

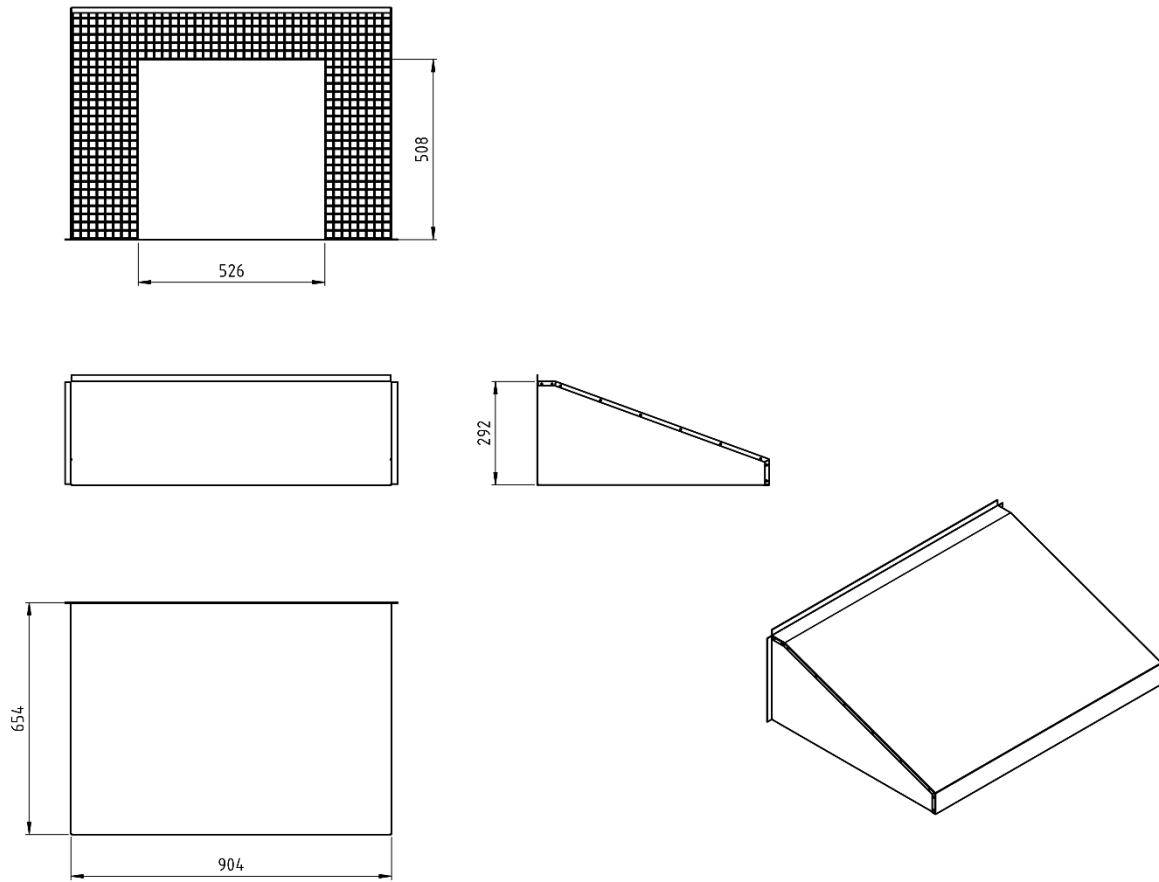

Intake/exhaust cowl 500*400

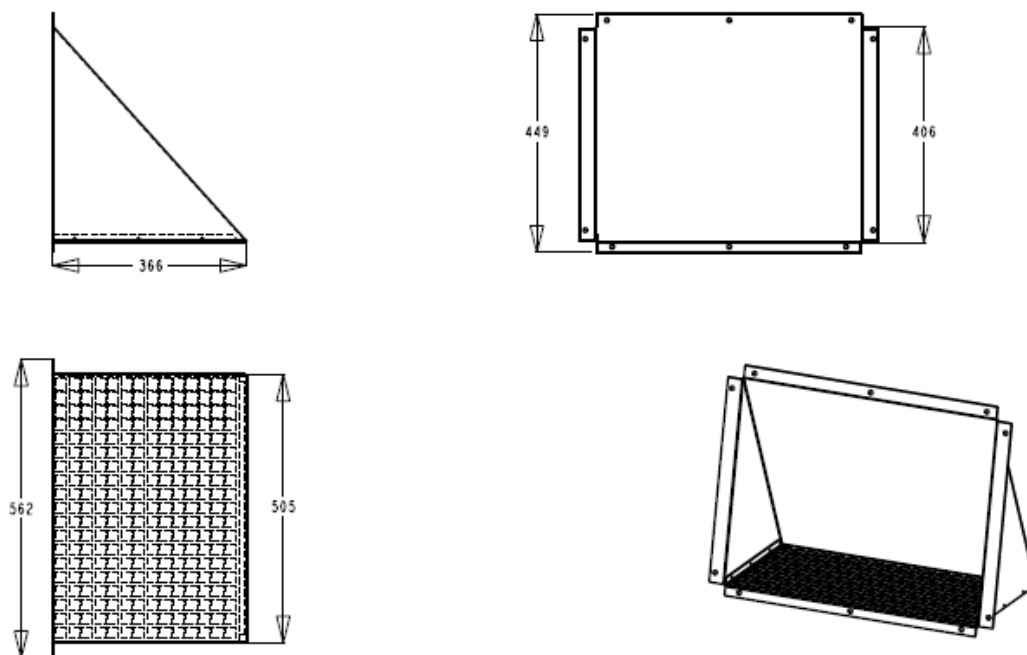

EC Declaration of conformity

This declaration is according to the Council Directive on the approximation of laws of the Member States relating to machinery 2006/42/EC.

Air-Site AB
Elementvägen 1
437 36 Lindome
Sweden

Hereby declare that the ODU Free Cooling Systems with type designations:
ODU-6L-48EC powered at 48 V DC

a) are manufactured in conformity with the Council Directive on the approximation of the laws of the Member States relating to machinery:
2006/42/EC; and

b) are, in addition to what is stated under a), manufactured in conformity with the following directives:

- 2006/95/EC (Low Voltage Directive)
- 2004/108/EC (EMC Directive)

c) comply with relevant parts of the following standards:

- EN ISO 12100:2010 (Mechanic);
- EN 60204-1:2006 (Electric);
- EN 61000-6-4:2006 (Emission for industrial environments);
- EN 61000-6-2:2005 (Immunity for industrial environments).

provided the electric power supply circuits to the equipment are to be equipped with automatic disconnection of the supply in accordance with ETSI EN 300 132-2.

Gothenburg 2013-02-15



Tomas Nilsson
Managing Director



NIBE Airsite AB
Elementvägen 1
S-437 36 Lindome
Sweden
Phone +46 31 995 114
Fax +46 31 990 114
www.nibeairsite.com