

MicroMaster FreeCooling Fan

MicroMaster 48EC and 230EC

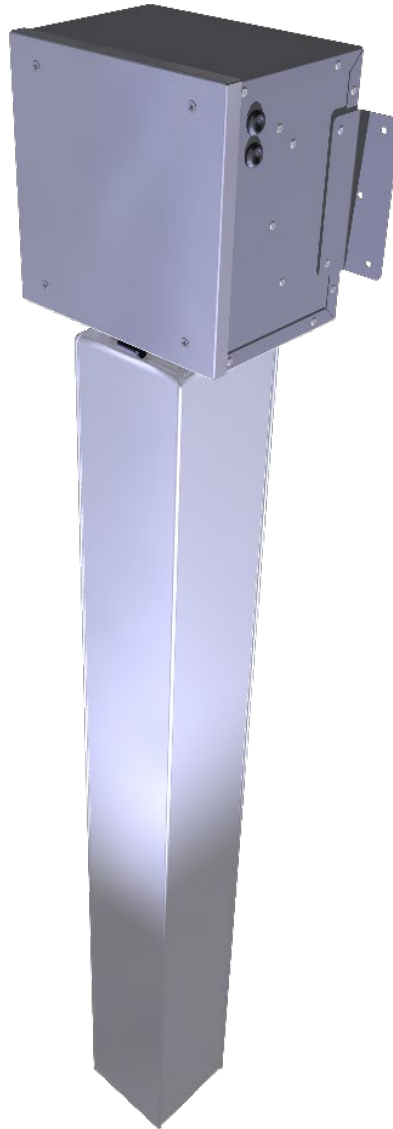

Eng

Installation, Operation and Maintenance instructions

Introduction

This document covers the installation, operation and maintenance of AirSite® MicroMaster Free Cooling unit. It consists of basic information and recommendations concerning design, installation and operation to ensure proper operation of the unit.¹

Please make sure to study this document thoroughly and follow all given guidelines and comply with the safety requirements.

MicroMaster is available in two different designs;

- MicroMaster 48EC is intended for installations where the power supply is 48V DC
- MicroMaster 230EC is intended for installations where the power supply is 230V AC

Index

Drawing of MicroMaster 48EC/230EC	3
Accessories	4
Principle diagram.....	5
MicroMaster 230EC.....	6
MicroMaster 48EC.....	6
Circuit diagram MicroMaster 230EC with X04	7
Circuit diagram MicroMaster 48EC with X04	8
Functional description X04 Control Unit.....	9
Installation instructions.....	10
Maintenance, service and repair.....	12
EC Declaration of conformity	13

Note! Any maintenance or installation must be done by a qualified or well instructed personnel.

Before energizing:

- Make sure that the intake cowl is mounted, and that all filters are installed in order to protect personnel against unintentional contact with fan parts in motion. There is risk for personal injury if a body part comes near the fan parts.



Before performing any installation or service, please make sure that:

- The power supply is off (Switch disconnecter or unplug plug/socket etc.)
- The fan impeller has come to a complete standstill
- You observe all personnel safety regulations!



When working near the MicroMaster's lower parts:

- Be careful about hitting your head and shoulders in the filter box's edges, corners or the filter connections.



When installing sheet metal parts with sharp edges like the unit's connection plate:

- Use protective gloves.



When changing filters:

- Use protective gloves to prevent your body from soil and bacteria.
- Gently lower the old filter bags in a plastic bag and seal it immediately.



¹ AirSite reserves the right, without prior notice, to make changes and improvements to the contents of this manual.

Drawing of MicroMaster 48EC/230EC

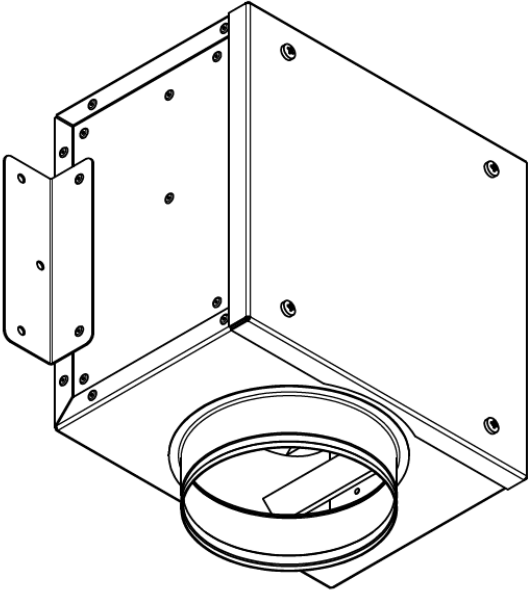
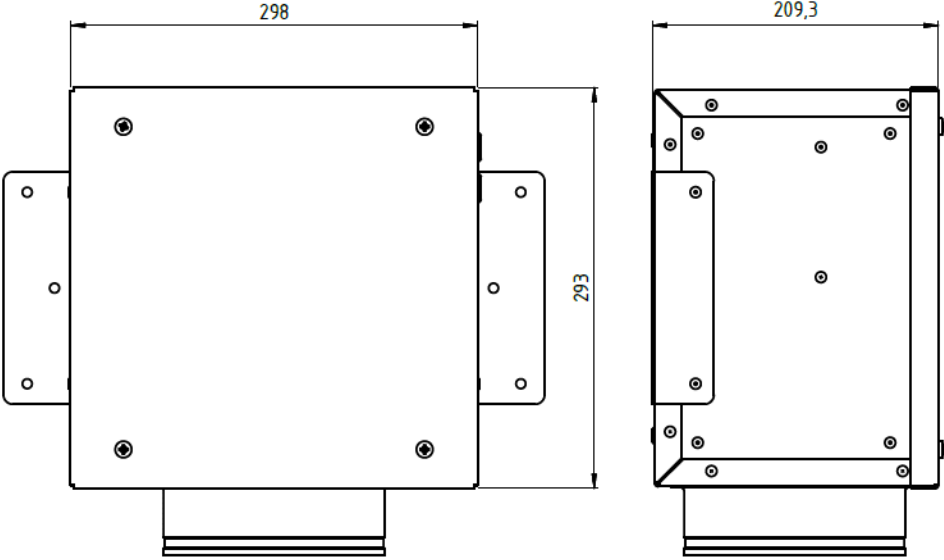

Accessories

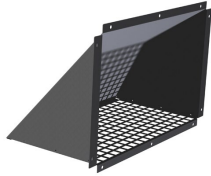

Intake/exhaust cowl



Exhaust backdraught damper



Damper with motor



Supply intake grille



Fan heater 1300W



Fire damper



Smoke detector



Angular part



Wall led thru



GSM/GPRS SIOX modem

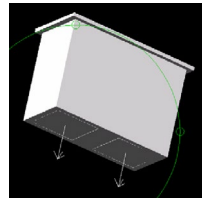

Intake/exhaust roof led thru

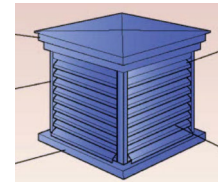

Intake roof cowl (City sites)

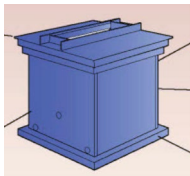

Exhaust roof cowl (City sites)

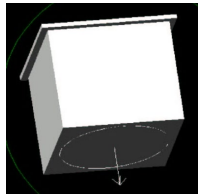

Roof led thru

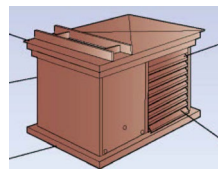

Intake/exhaust (City sites)

Principle diagram

The system is intended for climate control in equipment-, server rooms and alike.

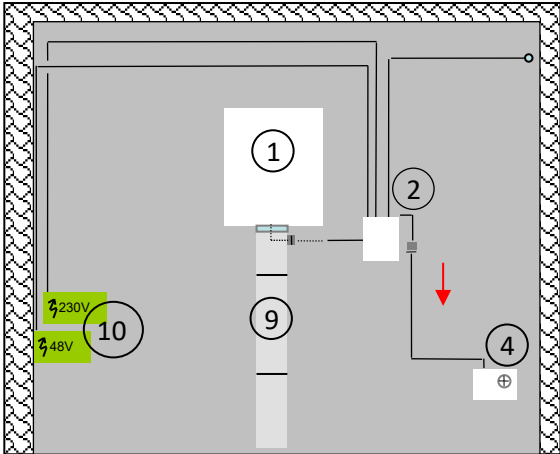
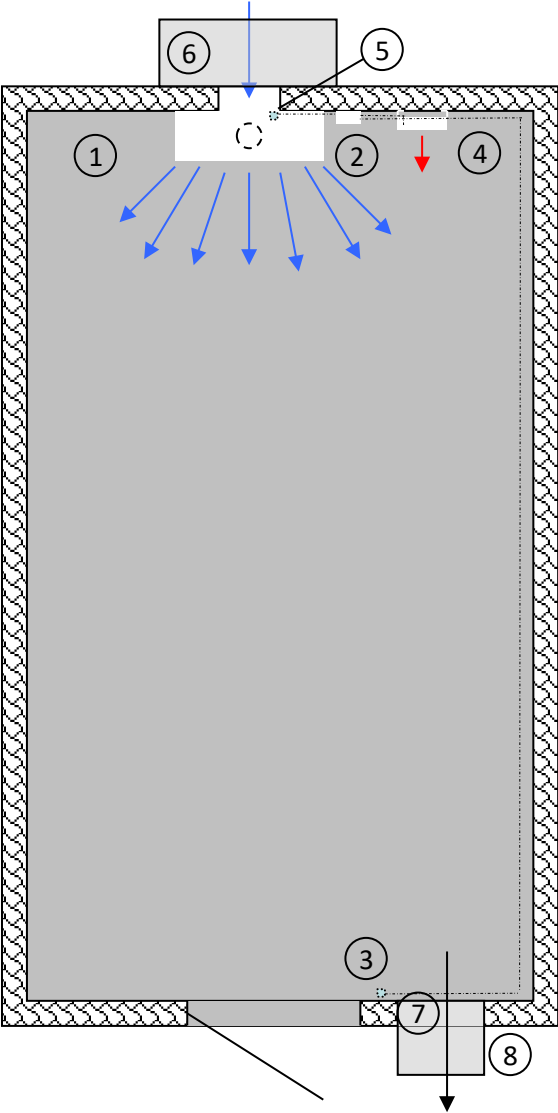

- 1. MicroMaster
- 2. X04 Control Unit
- 3. Indoor temp. sensor
- 4. Electric fan heater
- 5. Outdoor temp. sensor
- 6. Air intake cowl
- 7. Exhaust backdraught damper
- 8. Exhaust air cowl
- 9. Filter bag
- 10. Power supply

Product information

MicroMaster 230EC

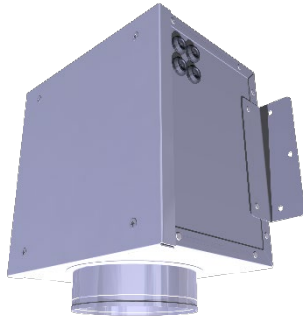

Contents:

- Galvanized steel-sheet fan casing, in painted or unpainted design.
- EC-fan with external rotor motor
- 1 pcs hose clamp, \varnothing 160 mm
- 1 pcs M6-160-1500 filter bag
- 1 pcs outdoor temp. sensor
- 1 pcs Connection box

Electrical data fan unit:

- Voltage 230 V
- Rated power 170 W
- Rated current 1,45 A
- Speed 2900 rpm
- Sound pressure 73,9 dBA

Fan unit, air flow, dimensions and weight:

- 210 l/s measured with an external pressure at 50 Pa and with clean filter
- Permitted ambient temp. $-25^{\circ}\text{C} \dots +60^{\circ}\text{C}$
- Dimensions: See drawing on page 3.
- Weight 6 kg
- Max. cooling power capacity 2 kW at $\Delta T = 2-5 \text{ K}$

Classifications according to IEC:

- Fan motor: IP54
- Temperature sensor: Protection Class II
- Connectors: IP20

Product information

MicroMaster 48EC

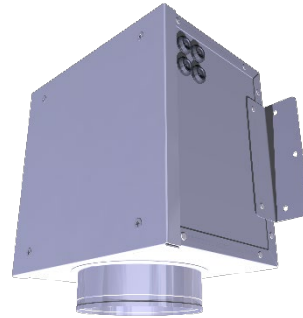

Contents:

- Galvanized steel-sheet fan casing, in painted or unpainted design.
- EC-fan with external rotor motor
- 1 pcs hose clamp, \varnothing 160 mm
- 1 pcs M6-160-1500 filter bag
- 1 pcs outdoor temp. sensor
- 1 pcs Connection box

Electrical data fan unit:

- Voltage 48 V
- Rated power 95 W
- Rated current 2,2 A
- Speed 2700 rpm
- Sound pressure 67 dBA

Fan unit, air flow, dimensions and weight:

- 205 l/s measured with an external pressure at 50 Pa and with clean filters
- Permitted ambient temp. $25^{\circ}\text{C} \dots +60^{\circ}\text{C}$
- Dimensions: See drawing on page 3
- Weight 7 kg
- Max. cooling power capacity 2 kW at $\Delta T = 2-5 \text{ K}$

Classifications according to IEC:

- Fan motor: IP42
- Temperature sensor: Protection Class II
- Connectors: IP20

Circuit diagram MicroMaster 230EC with X04 Control Unit

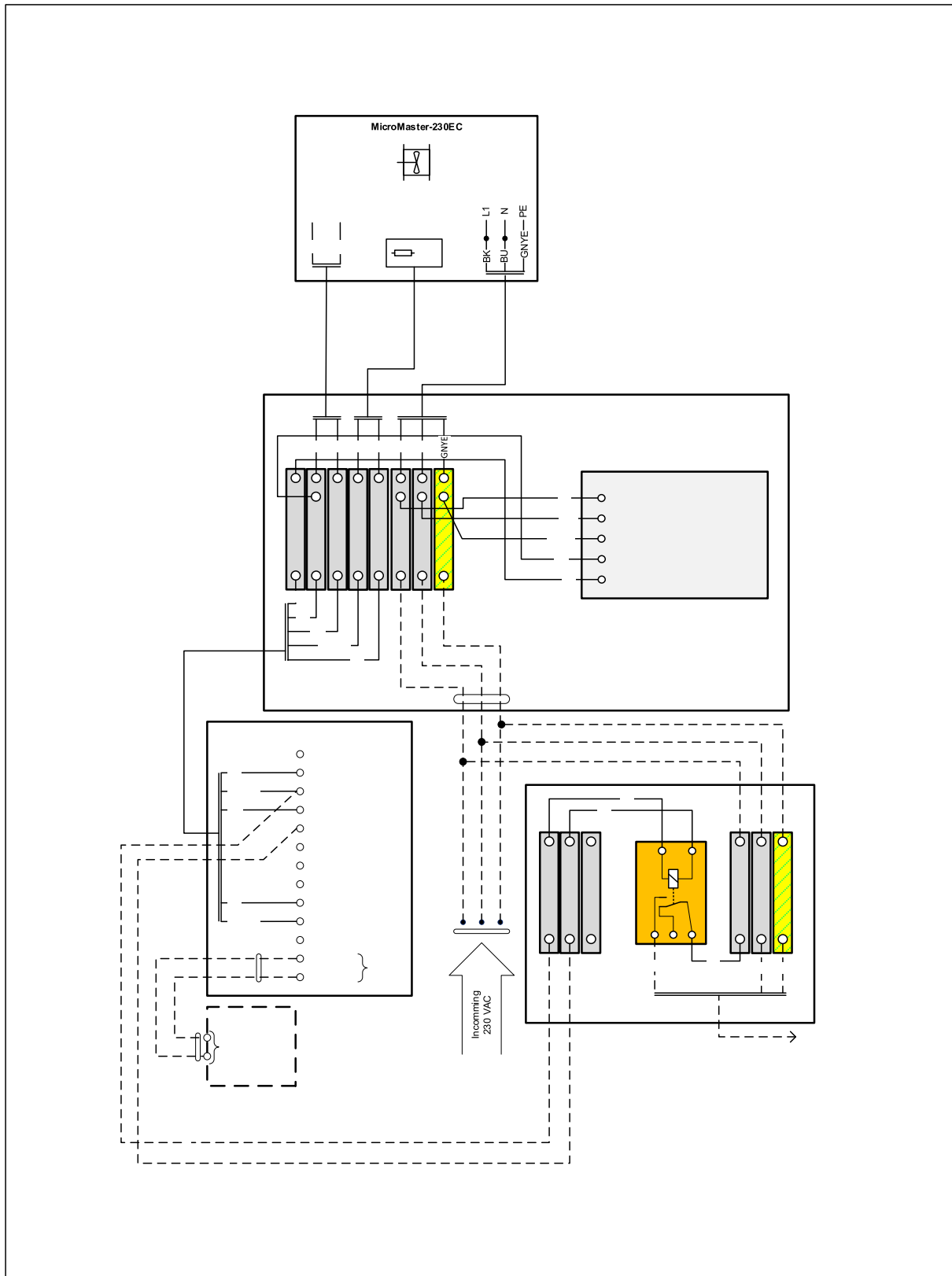

NIBE AirSite

X04 Connection box 1R MM 230EC

Type designation:

MicroMaster 230EC

Designed by:
JA

Approved by:
SN

Released date:
2019-01-16

Document No:
01111+X04&FS

Page:
1(1)

Circuit diagram MicroMaster 48EC with X04 Control Unit

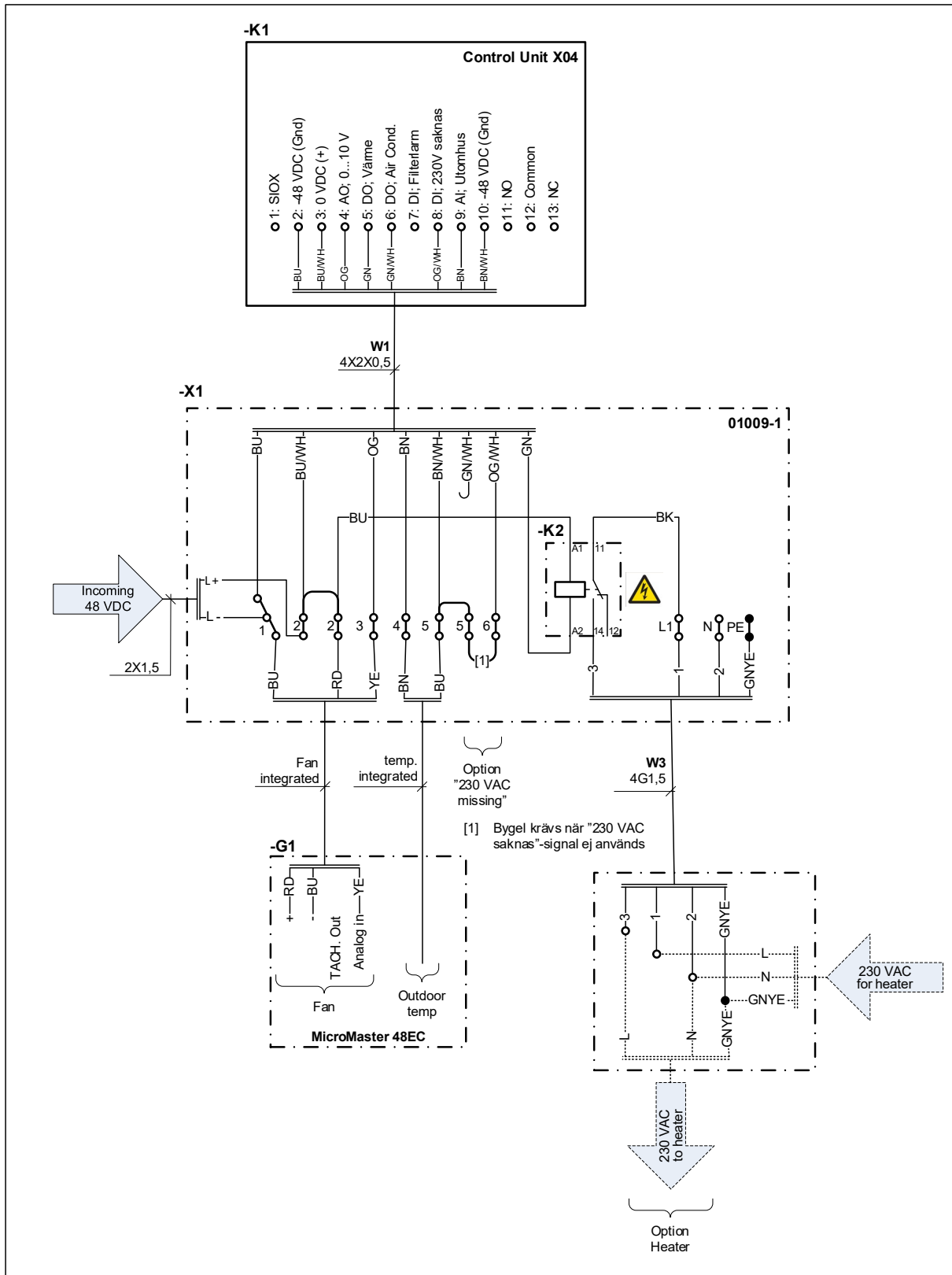

X04 Connection box 1R MM 48EC Type designation: **MicroMaster 48EC**

Designed by: JA	Approved by: SN	Released date: 2019-01-16	Document No: 01161+X04&FS	Page: 1(1)
---------------------------	---------------------------	-------------------------------------	---	----------------------

Functional description X04 Control Unit

Fan speed controlled by indoor/outdoor sensor.

The fan speed is controlled by the difference between indoor and outdoor temperature. As the indoor temperature increases so does the fan speed. As the temperature decreases so does the fan speed, until it reaches a minimum value (adjustable). If the heater is on, the FreeCooling fan is off.

The user-configurable delta T value denotes at which outdoor temperature below the selected set point that the regulator's set point value starts to be calculated as the sum of the outdoor temperature and the delta T temperature. Thus, the set point will follow the outdoor temperature at delta T degrees higher.

Heater

When the indoor temperature falls below 15°C (adjustable) the electric Heater/Fan unit is activated.

Air conditioning mode

Chose air conditioning mode in the Visual-SIOX software setup.

Air conditioner controlled by the indoor temp.

(Mode A)

Air Cond starts when the indoor temp is higher than the reference value + P-band + dead zone. Air Cond is then active during an adjustable period (180 minutes). During this period the Air Cond is controlled by its own internal control system. If the Air Cond equipment lacks an own control system, a hysteresis can be designated and the T10 relay that controls the Air Cond is switched on and off by the indoor temperature settings.

Air conditioner controlled by the outdoor temperature

(Mode B)

When this mode is chosen, it is pivotal to install the outdoor sensor out of reach of direct sun. This mode is chosen by setting a temperature limit value for the outdoor temperature in the menu. If the limit is set to 0, the Air Cond is controlled as in mode (A) above. In this mode the Air Cond starts when outdoor temperature is above the set temp. In case of malfunctioning outdoor sensor the AC is controlled by the inside temperature. In both A and B modes the fan unit is stopped when the Air Cond runs. If the indoor temp is higher than 30°C, 30 minutes after the AC has started, the fan unit will start again automatically.

Service timer

During normal operation, if the function button is pressed in for about 5 seconds, the free cooling fan is switched off for 15 minutes (adjustable). If the button is pressed again before this period has expired, the free cooling fan will restart.

Alarms

The alarm relay will close at power-on and open in case of an alarm. The relay is not latching; it will close again as soon as the causes for the alarm no longer exist.

A-alarm =the LED will signal a steady red light.

B-alarm =the LED will signal a flash red light.

High temperature

FreeCooling fan is running with high speed when high temp alarm is activated.

Low temperature

Heater is switched on, FreeCooling is off.

Filter alarm

The alarm relay opens when there is a certain Δt between indoor and outdoor temperature. Examples for such conditions are: full filter, dirty intake grill, dirty intake mesh or when the free cooling unit is under-dimensioned.

Test mode

During normal operation, if the function button is pressed in for about 10 seconds the test sequence will start.

Stage 1: Free cooling fan starts.

Stage 2: The heater unit starts.

Stage 3: Air-conditioning starts.

Stage 4: Testing the room high and low temperature alarm.

Move the lever to "max" for testing high temp alarm. Move the lever to "min" for testing low temp alarm.

Please press the function button once to step through the stages above. Normal operation starts after 30 minutes if no button is pressed.

Alarm and operations indicators

The led lights green when freecooling is activated and slowly flashing green when air-cond or heater is running. Service is showed by green flash fast short-long. All alarms have red lights

Main supply

24V/48V DC

Settings

Change settings via computer. Wire between X04 and computer.

Connections possibilities

- Serial connection to PC Visual SIOX.
- Connection to external modem.
- Connection to TCP/IP with external gateway.

Installation instructions

Intake cowl:

Recommended hole size in outer wall is:
 $\geq \varnothing 200$ mm, or 220x220 mm for the
MicroMaster.

Distance between hole center and indoor floor
should be:
ca 1700 mm for the MicroMaster.

If the outer wall isn't flat, use a protection
sheet (Size 527x343). Cut a hole in the sheet –
as large as the hole in the wall – and mount it
from the outside according to the drawing
below:

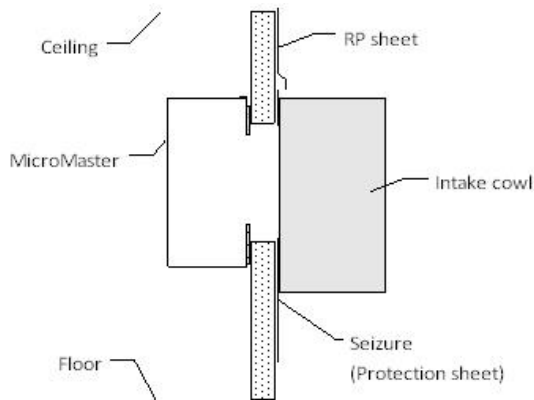

In order to prevent fiber release from wall
insulation, a wall led thru should be mounted
in the wall. Install from the inside of the wall.



Fig. 1: Wall led thru

Mount intake cowl and Rain Protection (RP)
sheet according to the drawing above. Be sure
to seal between all open areas!

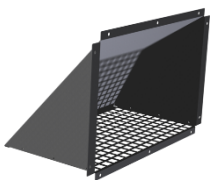

Fig. 2: Intake cowl 645x300.

MicroMaster

Mount the MicroMaster to the inside wall by
using the pre mounted wall fastenings.
Make sure to center the fan to the hole in the
wall.

Mount the filter bag with the supplied hose
clamp. Do not connect to the mains before
the filters and the intake cowl are mounted
and in place.



Fig. 5: MicroMaster with filter mounted

Installation of exhaust unit:

Cut a hole in the wall so that the exhaust back
draught damper fits. **Note!** Distance between
the hole bottom edge to the floor should be at
least 1600 mm.

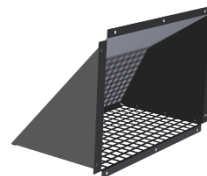

Fig. 6: Exhaust cowl 465x300

Mount the backdraught damper* into place
with cowl mesh on the inside of the outer
wall. Mount the exhaust cowl. Use sealing
between cowl and outer wall.



Fig. 7: Mounted backdraught damper in wall

* Air-Site delivers telescopic backdraught dampers as standard, which means that one part is mounted from the inside and one from the outside. So-called Basic dampers (w/o telescope) also occur in some cases. Basic dampers are mounted from the inside so that the louvers open outwardly to the cowl. Mount rain protection sheet if needed. Seal between all open areas.

Control unit; Alt. X04 with connection box

Connect cables according to the connection diagram included in this manual. 230V and 48V power supply cables are not included.

Outdoor temperature sensor and fan are mounted inside the MicroMaster unit. Connect these to the connection box using the included quick connectors.

Mount X04 on the wall, 1.5 m above the floor. Place X04 as far away from MicroMaster – and near the exhaust air – as possible. Use countersunk screws when mounting the X04 casing on the wall, so that they do not damage the back of the circuit board.

The user must hold the following:

1. Selection, installation and connection of power cables for 48 V DC and 230 V AC.

Minimum cable diameter is 1,5 mm² for both feeds. Maximum allowable voltage drop is 5 %.

2. The supply cables for 48 V DC and 230 V AC must be protected against overcurrent (set values for 48V should not exceed 6 A and must not exceed 10 A).
3. Automatic disconnection of 230 VAC supply in order to protect the personal safety against electric shock by indirect contact in accordance with EN IEC 60204-1 section 6.3.3 (equivalent to IEC 60364-4-41 section 413.1, or for Sweden SS 436 40 00 section 413.1).

Means for disconnection must be arranged in the feeding circuitry of 230 V AC and 48 V DC.

Such disconnection devices shall preferably be made in accordance with EN IEC 60204 1 section 5.3: "Supply disconnecting (isolation) device".

Since risks of mechanical maintenance work on a "Free Cooling Unit" like this are small, the can also be carried out under IEC 60364 5 53 section 536.2 "Isolation" or SS 436 40 00 section 536.2 "Separation".

A possible solution with plug connections must not allow confusion between the means of connection for 230 V AC and 48 V DC.

Maintenance, service and repair

Before performing any installation or service, please make sure that:

- Power supply is off (Disconnect or, plug/socket etc.)
- Fan impeller has come to a complete standstill
- You observe all personnel safety regulations!

Fan:

The fan should be cleaned when necessary to avoid unbalance and unnecessary damage to the bearings. The fan bearings are maintenance free and should only be changed if necessary. Do not use a High pressure cleaner (steam jet) when cleaning the fan! Make sure the fan impeller's balance weights are not moved or the fan impeller distorted. Listen for abnormal operating noise.

Filters

Filters should be changed at least every two years or more frequently if needed.

Air intake

Inlet must be cleaned of leaves and dust to maintain a high air flow.

Exhaust air

Make sure the backdraught damper properly closes when the fan is cut off.

EC Declaration of conformity

This declaration is according to the Council Directive on the approximation of laws of the Member States relating to machinery 2006/42/EC.

Air-Site AB
Elementvägen 1
437 36 Lindome
Sweden

Hereby declare that the **MicroMaster** free cooling systems with type designations:
48EC, 230EC

a) are manufactured in conformity with the Council Directive on the approximation of the laws of the Member States relating to machinery:

- **2006/42/EC**; and

b) are, in addition to what is stated under a), manufactured in conformity with the following directives:

- **2006/95/EC** (Low Voltage Directive)
- **2004/108/EC** (EMC Directive)

c) comply with relevant parts of the following standards:

- **EN ISO 12100:2010** (Mechanic)
- **EN 60204-1:2006** (Electric)
- **EN 61000-6-3:2007** (Emission for residential, commercial and light-industrial environments)
- **EN 61000-6-2:2005** (Immunity for industrial environments)

provided the electric power supply circuits to the equipment are to be equipped with automatic disconnection of the supply in accordance with ETSI EN 300 132-2.

Gothenburg 2014-01-06



Tomas Nilsson
Managing Director

AirSite | **NIBE**
GROUP MEMBER

AirSite AB
Elementvägen 1
S-437 36 Lindome
Sweden
Phone +46 31 311 32 00
www.airsite.eu

Art. no 8016616 IMO EN 2335-1 MicroMaster